



GT Detector

Product User Manual

CAT# GT-12101

Human Identification Kit for
Multiplex Amplification of
Autosomal Chromosome STR loci

Produced by

GENETEK BIOPHARMA GmbH

Contents

1. GT Detector Overview	4
1.1 Intended Use	4
1.2 GT Detector Markers	4
1.3 Five-dye fragment analysis	6
2. PCR	7
2.1. Storage Condition	7
2.2. Materials and equipment.....	7
2.2.1. Laboratory condition	7
2.2.2. Material required for Fragment Analysis	7
2.2.3. PCR Amplification by GT Detector.....	8
2.2.4. GT Detector components.....	8
2.2.5. GT Detector protocol	8
3. Capillary electrophoresis	10
3.1. Instrument Preparation for Applied Biosystems® 3500/3500xL Genetic Analyzer (before the first use of GT Detector Kit).....	10
3.1.1. Create a new Instrument Protocol	12
3.1.2. Create a New Size Standard for the QC protocol.....	12
3.1.3. Create a QC protocol.....	13
3.1.4. Create a new Assay	14
3.1.5. Create a new File Name Conventions	15
3.1.6. Create a new Result Group	16
3.1.7. Create a New Plate	17
3.1.8. Select “Assign Plate Contents”	18
3.2. Instrument Preparation for Applied Biosystems® 3130/3130xl Genetic Analyzer (before the first use of GT Detector Kit).....	20
3.2.1. Create a Run Module	21
3.2.2. Create an Instrument Protocol	22
3.2.3. Set up a Plate for run.....	23
3.2.4. Fill out the New Plate Dialog.....	24
3.2.5. Fill out the GeneMapper Plate Editor	25
3.3. Sample preparation for capillary electrophoresis (3500 Series and 3130 Series instruments)	28
4. Result analysis and Interpretation	29

4.1. Software for sample analysis	29
4.2. General guideline for the analysis of GT Detector results	29
4.3. GT Detector Allelic Ladder.....	31
5. An examples for GT Detector result.....	33
6. Troubleshooting	35
7. Limitations and Disclaimer	38
8. General Safety Warnings	39
9. Symbols used on labels and packaging.....	40
10. Further Reading	41

1. GT Detector Overview

- Easy to use multiplex PCR - amplification of 17 markers in a single reaction
- 16 STR specific to autosomal chromosome loci and the Amelogenin marker for sex determination
- For forensic applications and in complex kinship cases
- Can be used on extracted DNA from blood or blood on DNA banking card or diluted blood using GT Blood Diluting buffer.
- Analyzed using 5-dyes capillary electrophoresis system. Compatible with the Compact Spectrum CE System from Promega and Applied Biosystems™ 3130/xl, 3500, 3500/xl, SeqStudio platforms.

1.1 Intended Use

The GT Detector Kit is intended for molecular biology applications in forensic, human identification, and kinship issues. This product is not intended for the diagnosis, prevention, or treatment of a disease.

1.2 GT Detector Markers

STR loci (short tandem repeat) consist of short and repetitive sequence elements, 2 - 7 base pairs in length. These tandem repeats are well distributed throughout the human genome and are a rich source of highly polymorphic markers which can be detected by PCR using primer from their flanking sequences. The STR loci alleles are differentiated by the number of copies of the repeat sequence contained within the amplified region (locus) and are distinguished from each other using fluorescence detection after capillary electrophoretic separation.

GT Detector markers are designed in such way that distribution of loci covers most of the autosomal chromosomes (Table 1). Markers heterozygosity and SNP in their primer sites were tested on several hundred DNA samples.

GT Detector Kit comprises primers in a multiplex format which amplifies 16 loci on different autosomal chromosomes and a sex-determination marker AMXY on the Amelogenin gene. Out of 17 markers, 13 markers are from CODIS core loci (i.e. CSF1PO, FGA, TH01, TPOX, vWA, D3S1358, D5S818, D7S820, D8S1179, D13S317, D16S539, D18S51, and D21S11). Additionally, SE33, D19S433 and D2S1338 markers are also included to increase discrimination power and allow searching national or other databases that had been produced using CODIS containing loci.

Table 1. Markers in GT Detector Kit

No.	Marker	Size Range	Chr. Location
1	AMXY	103-120	Xp22.2
			Yp11.2
2	D7S820	140-191	7q21.11
3	D21S11	193-255	21q21.1
4	VWA	260-315	12p13.31
5	D3S1358	338-387	3p21.31
6	D19S433	125-176	19q12
7	D8S1179	177-239	8q24.13
8	D13S317	252-300	13q31.1
9	CSF1PO	302-346	5q33.1
10	D2S1338	357-422	2q35
11	TH01	100-140	11p15.5
12	D5S818	156-207	5q23.2
13	TPOX	220-267	2p25.3
14	SE33	310-440	6q15
15	D16S539	110-152	16q24.1
16	D18S51	185-265	18q21.33
17	FGA	280-350	4q28

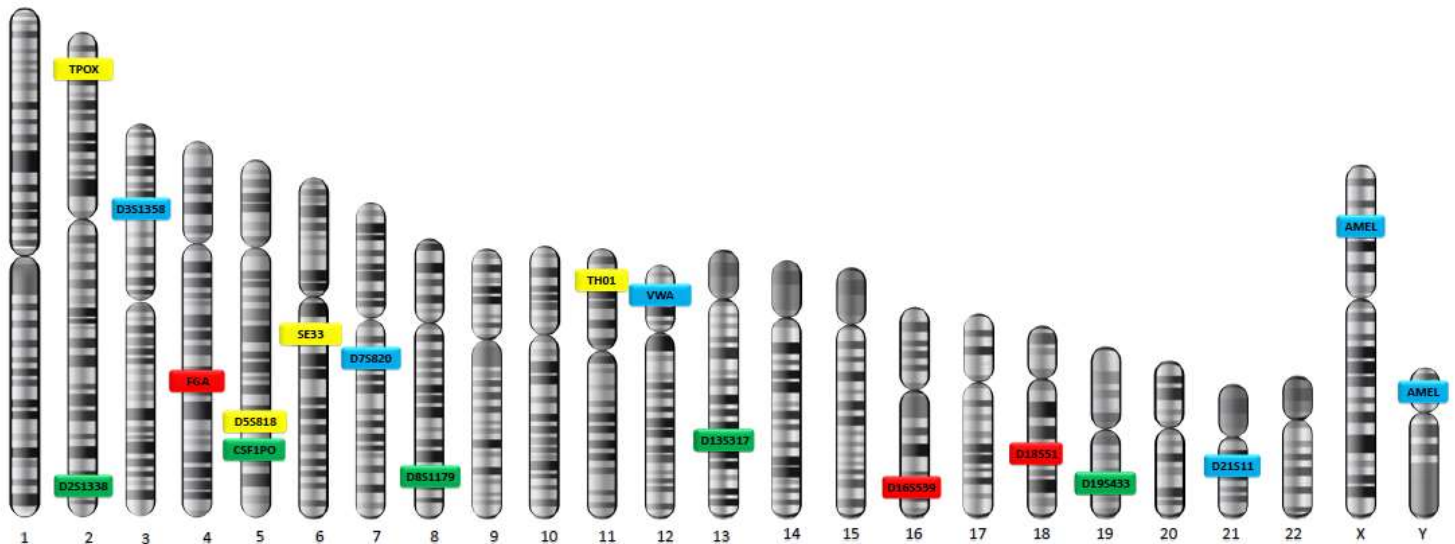

Figure 1. Diagram shows distribution and placement of GT Detector Kit markers on Human Chromosomes.

1.3 Five-dye fragment analysis

ABI 3130, 3130xl, and 3500 and 3500xL Genetic analyzers (Applied Biosystems®) are recommended for 5-dye capillary electrophoresis of amplified products.

Table 2. The fluorescent dyes used in GT Detector kit

Name	6-FAM	GT2907	GT2712	GT1803	GT500
------	-------	--------	--------	--------	-------

GT Detector Markers

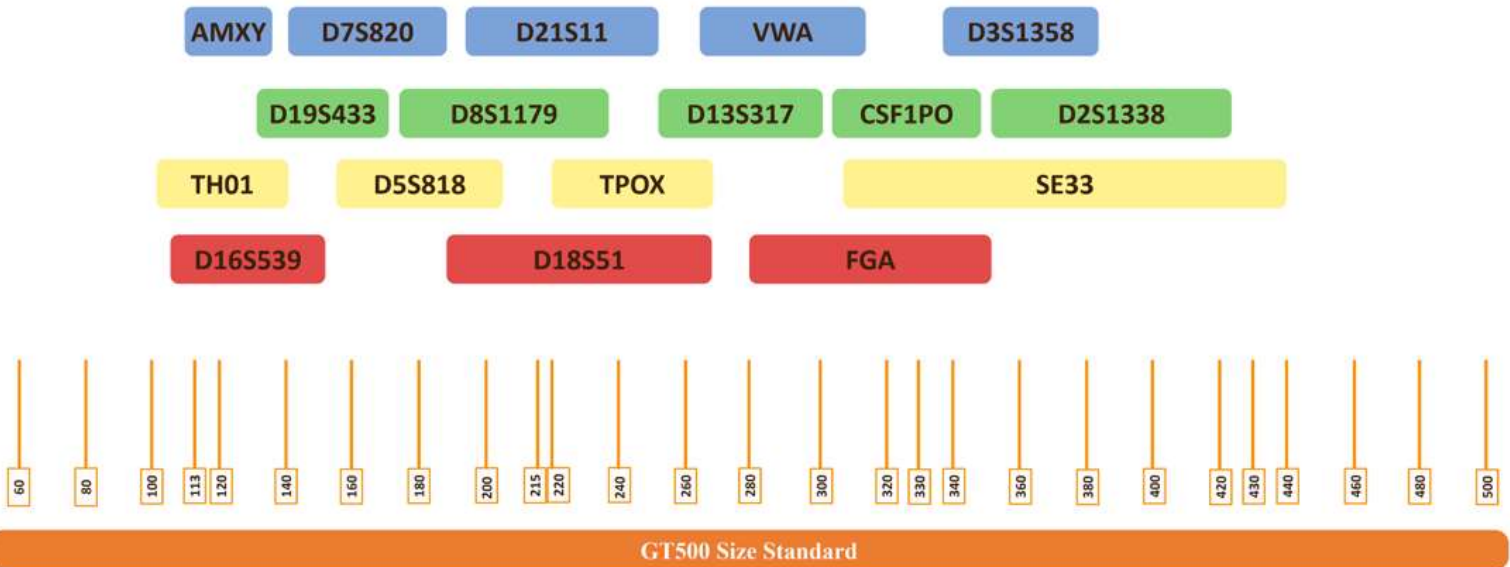

Figure 2. Diagram shows distribution and placement of GT Detector Kit markers with GT500 Size Standard.

2. PCR

2.1. Storage Condition

- Store at -20 °C
- Keep the primer mix in a dark place (because of fluorescently labelled primers)
- Avoid frequent freeze and thaw (store the materials in small aliquots)
- Low-quality result may be obtained after the expiration date (12 months)









2.2. Materials and equipment

2.2.1. Laboratory condition

Fluorescent based STR kits can amplify a small amount of DNA. So care should be taken not to contaminate the working area. Primer Mix, PCR Mix and GT HSTaq DNA polymerase should be stored in a separate lab (Pre-PCR area). GT500 Size Standard, GTM5 v2 Matrix Standard and GT Detector Allelic ladder are amplicons and should be stored in post-PCR area. In each run, negative control should be added to determine possible and source of contamination. We recommend that DNA from each personnel working in the lab be profiled so in case of contamination, the source can be determined and precautionary measures can be taken.

2.2.2. Material required for Fragment Analysis

Table 3: Table 1: Provided with the Kit in Box A and Box B. They should be kept separately. Box A in one freezer and Box B in another freezer (PCR product)

BOX-A			BOX-B		
	Tube Label	Tube cap colour		Tube Label	Tube cap colour
1	PCR Mix		1	GT500 Size Standard	
2	Primer Mix		2	GT Detector AL	
3	GT HSTaq		3	GTM5 v2 (Optional)	
4	GT QCDM102 (Control DNA-50ng/μl)				
5	GT QCW (H2O)				

Not provided with GT Detector (but are needed)

- Reagents and equipment for DNA extraction
- Equipment and consumable for amplification (i.e. Thermal Cycler, Micropipette, Filter Tips etc.)
- Applied Biosystems Genetic Analyzer (ABI 3130/xl or 3500/xL) with Data Collection software for 5-dye system detection
- Applied Biosystem Genetic Analyzer (ABI 3130/xl or 3500/xL) relevant Performance optimized polymers (i.e. POP-4, POP-6 or POP-7) and Capillary Array or equivalent
- Applied Biosystems Hi-Di™ Formamide or equivalent
- GTM5 v2 Matrix Standard for Spectral calibration (GT- 41103) (can be obtained from Genetek Biopharma).

2.2.3. PCR Amplification by GT Detector

- DNA can be extracted from blood, bone, teeth, saliva, samples. This kit also works on blood/saliva samples on filter paper such as DNA Banking Card (DBC™). For instruction on direct PCR method please consult us by email (support@genetek.de).
- 1-5 ng DNA can be used as a template
- For optimizing and getting the best results, internal validation for each laboratory is recommended.

2.2.4. GT Detector components

Table 4: PCR reaction set-up

Component	Volume for 1 reaction[μ l]
GT QCW (H ₂ O)	10
PCR Mix	7
Primer Mix	1
GT HSTaq	1

2.2.5. GT Detector protocol

- Bring reagents to room temperature.
- Vortex Primer Mix and PCR Mix, then spin down briefly to remove all residues from the lid. Gently mix the enzyme by inverting or pipetting.
- Prepare a Master Mix calculating number of samples and controls following the recipe given above. Every preparation can be done at room temperature (no cold condition is required during preparation).
- Pipet mix or Vortex Master Mix briefly.
- Transfer 19 μ L of Master Mix into each 0.2 ml PCR tube for each sample.
- Add 1 of sample DNA (1-5 ng per reaction) into each PCR tube. Make one positive control PCR tube using the DNA provided in the kit and also for negative control add 1 μ l of sterile Direct Q dd H₂O instead of DNA.
- Vortex and spin down each PCR tube. Make sure that no drops are left at the tube wall or lid.
- Place tubes into thermal cycler.
- Use the following PCR program for the amplification of all markers.

Table 5: PCR program

Initial step	Cycling			Final Extension	Storing in Cycler
	Denaturation	Annealing	Extension		
95 °C	95 °C	63 °C	70 °C	70 °C	4 °C
20 min	1 min	90 sec	2 min	17-20 min	∞
27-30 Cycles					

- After completion of PCR, store the PCR products at 2-6°C until analysis with Genetic Analyzer.

Notes:

- PCR product is persistent for about 24h at room temperature. It is better to keep it in a refrigerator and in dark. for running on the Genetic Analyzer at later days.
- If the time between amplification and capillary electrophoresis is more than one week, the quality of results may be reduced.
- A positive control DNA (sample with known genotype) and a negative control should be run with each multiplex PCR. We recommend using GT QCDM102 as a positive control especially early on during the testing of our kit or setup. The result for this control DNA can be found from Genetek website and also in our latest user manual.
- According to the quantity of DNA template, you may require changing the number of cycles in PCR Program or the amount of DNA used.

Attention:

After PCR is complete, tubes should never be opened in the PCR setup area (pre-PCR area) or near the kit components.

3. Capillary electrophoresis

- ABI 3130/xL and 3500/xL (Applied Biosystems®) Genetic Analyzers are recommended for 5-dye capillary electrophoresis of the amplified PCR products.
- Please make sure your ABI Data Collection software supports 5-dye fragment analysis (according to the instrument user manual).
- GT Detector Kit is validated using 50 cm capillary array and POP7 as well as on 36 cm array and POP4 using ABI 3500xL (Applied Biosystems®).
- For more details and optimization, follow the user guide on [DNA Fragment Analysis by Capillary Electrophoresis by Applied Biosystems®](#).

Notes:

- Injection time or voltage can be adjusted according to the amount of PCR product.
- An increase or decrease in the injection time or voltage may result to run product through the capillary.
- PCR products can be injected into the capillary more than one time or the results can be re-analyzed.

3.1. Instrument Preparation for Applied Biosystems® 3500/3500xL Genetic Analyzer (before the first use of GT Detector Kit)

Make sure that maintenance and installation of capillary array, buffers and polymer is done according to Applied Biosystems 3500/3500xL Genetic Analyzer User Guide.

Attention:

Spectral Calibration must be made using GTM5 v2 Matrix Standard, the machine must be calibrated with GTM5 v2 Matrix Standard before using the kit. Please find detailed protocol for spectral calibration with GTM5 v2 Matrix Standard here - CAT# 41103 or contact us at support@genetek.de.

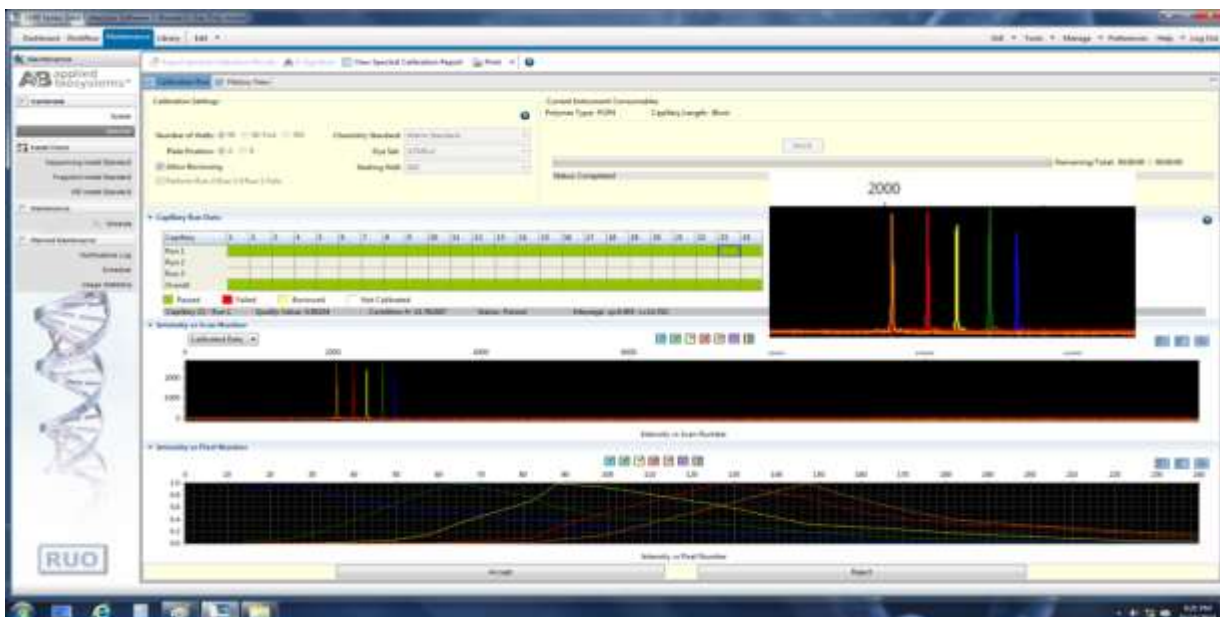

Figure 3. An example of a successful spectral calibration with GT 5-dye system on Applied Biosystems Genetic Analyzer 3500xL

- The Dashboard screen (Figure 4) is launched when 3500 Data Collection Software is opened. Click the Refresh button to make sure that all the information on the Dashboard is up-to-date. Make sure that the Maintenance and Consumables notifications are acceptable.
- Adjust the oven temperature to 60° C, then click “Start Pre-Heat” button. You may proceed for the first injection only after Oven Temperature and Detection Cell Temperature numbers turn green.



Figure 4. Dashboard of Applied Biosystems 3500 Data Collection software

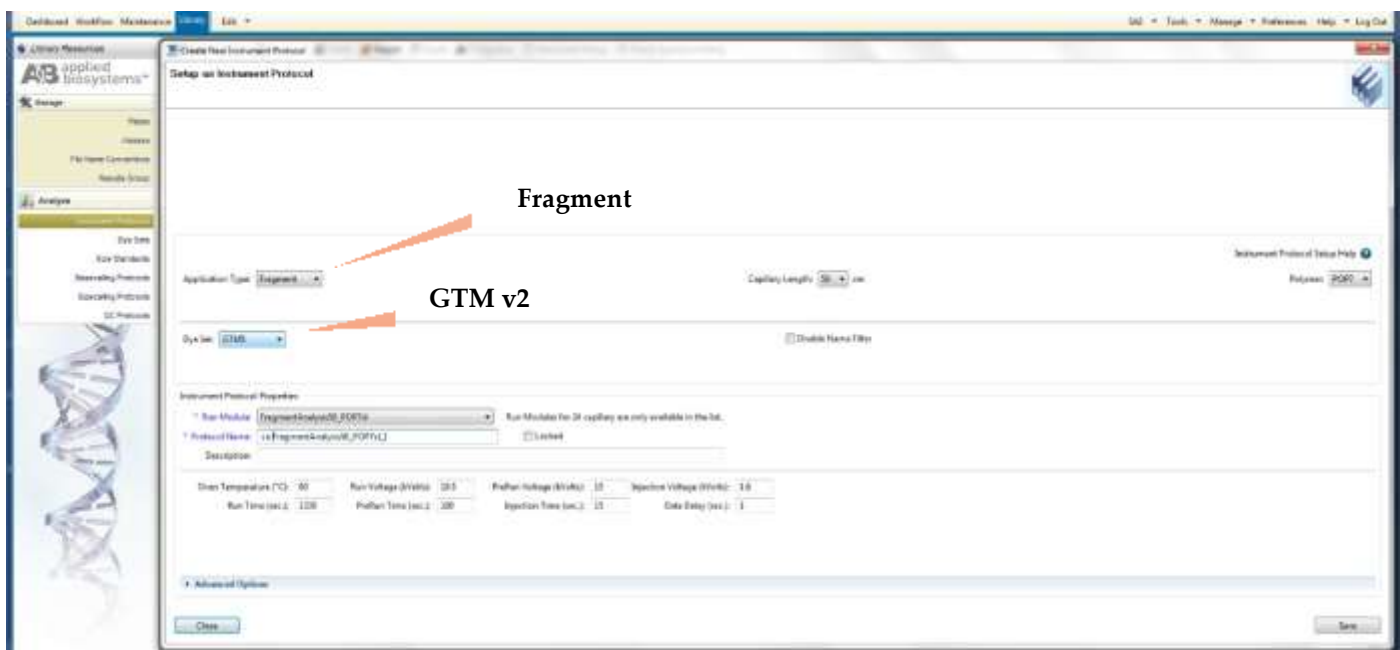

Figure 5. Screenshot for the “Create New Instrument Protocol” window on Applied Biosystems 3500 Data Collection software

- User can apply settings as shown in the Figure 5. Make sure that you select GTM5 v2 as a Dye Set (same name as was used to perform the GTM5 v2 spectral calibration).

Onset of first analysis of GT Detector system, User must create an Instrument Protocol, Size Standard, QC Protocol, Assay, File Name Convention and Results Group.

3.1.1. Create a new Instrument Protocol

- a) Navigate to the *Library*
- b) Select “Instrument Protocols”
- c) Select “Create” (Figure 5)

Data Collection Software will store this information (until there is a change in the physical properties of the instrument), and it can be used for consequent runs.

Alternatively, individual labs should validate and define the settings according to their results. For more detailed information, refer to the Applied Biosystems 3500/3500xL Genetic Analyzer User Guide.

3.1.2. Create a New Size Standard for the QC protocol

- a) Navigate to the Library
- b) Select “Size Standards”
- c) Select “Create” (Figure 6)

Data Collection Software will store this information (until there is a change in the physical properties of the instrument), and it can be used for subsequent runs.

- d) Name the Size Standard as “GT500” and as Dye Colour select “Orange”.

The fragments size in the GT500 Size Standard are 60, 80, 100, 113, 120, 140, 160, 180, 200, 215, 220, 240, 260, 280, 300, 320, 330, 340, 360, 380, 400, 420, 430, 440, 460, 480 and 500

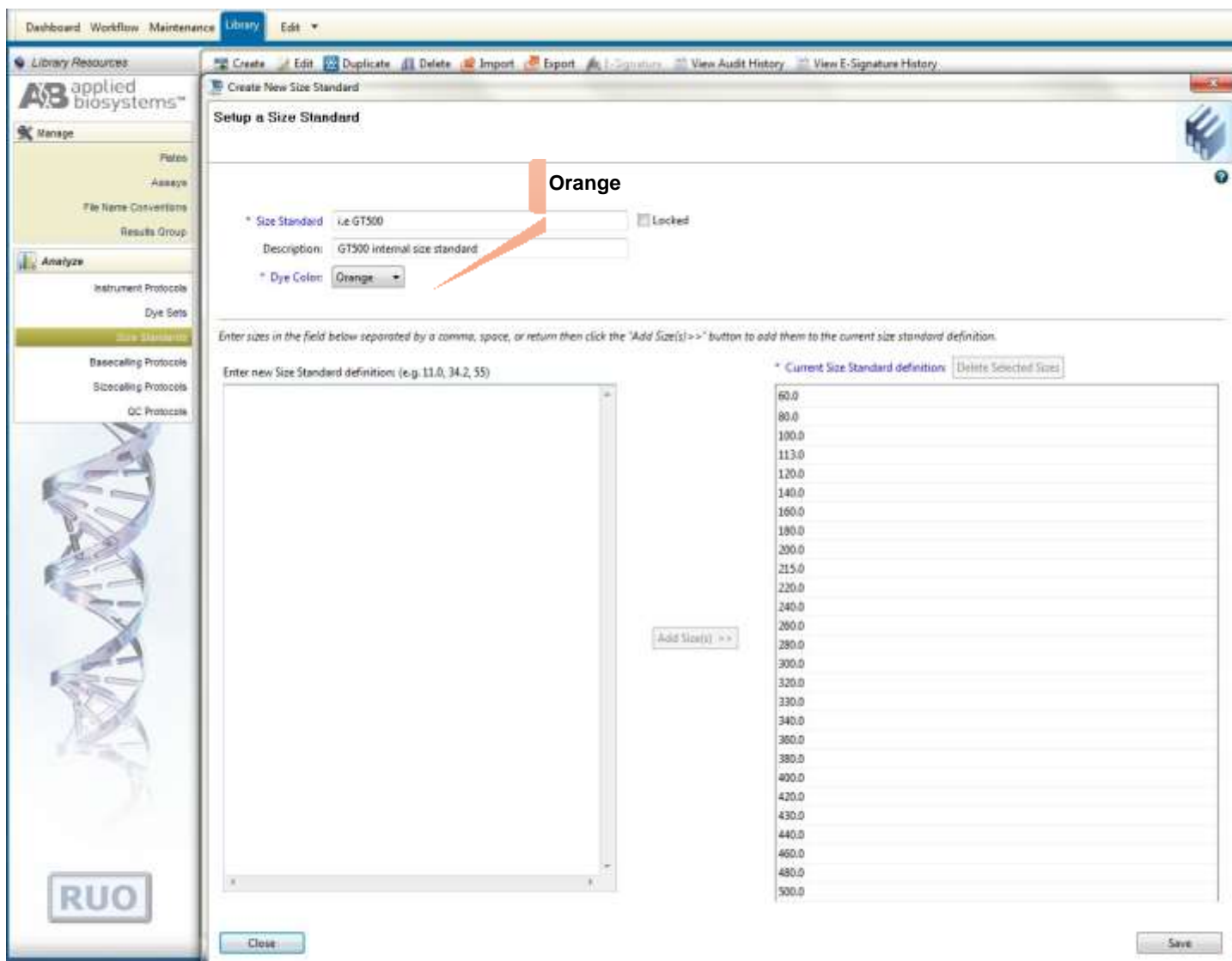

Figure 6. Screenshot for the “Create New Size Standard” window on Applied Biosystems 3500 Data Collection software

3.1.3. Create a QC protocol

- a) Navigate to the *Library*
- b) Select “*QC Protocols*”,
- c) Select “*Create*” (Figure 7)

The Data Collection Software will store this information (until there is a change in the physical properties of the instrument), and it can be used for subsequent runs.

- d) Name the Protocol as “i.e. *GT500*” and select the *Size Standard* “GT500”

Users can select settings as shown in the Figure 6 or alternatively may define these settings based on internal validation condition for GT Detector on the Applied Biosystems® 3500/3500xL Genetic Analyzer.

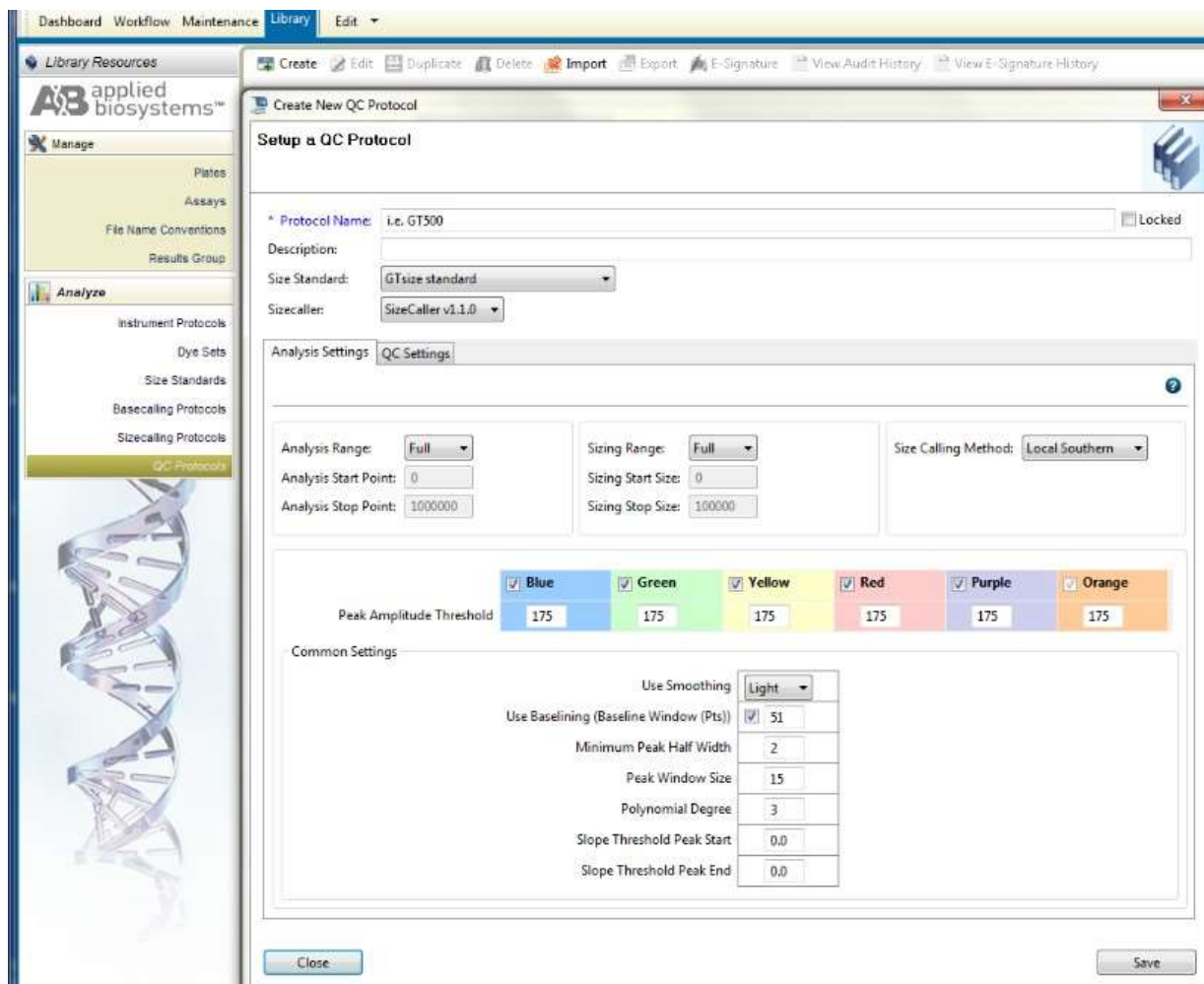

Figure 7. Screenshot for the “Create New QC Protocol” window on Applied Biosystems 3500 Data Collection software

3.1.4. Create a new Assay

- a) Navigate to the Library
- b) Select “Assays”
- c) Select “Create” (Figure 8)

Data Collection Software will store this information (until there is a change in the physical properties of the instrument), and it can be used for subsequent runs.

- d) In the *Create New Assay window*, as shown in Figure 8, choose the Instrument Protocol created in Step 3.1.1 and the QC Protocol created in Step 3.1.3.
- e) Give a name to the assay.
- f) Choose the application type “*Fragment Analysis*”.

Any named sample on the plate must have an Assay assigned to it.

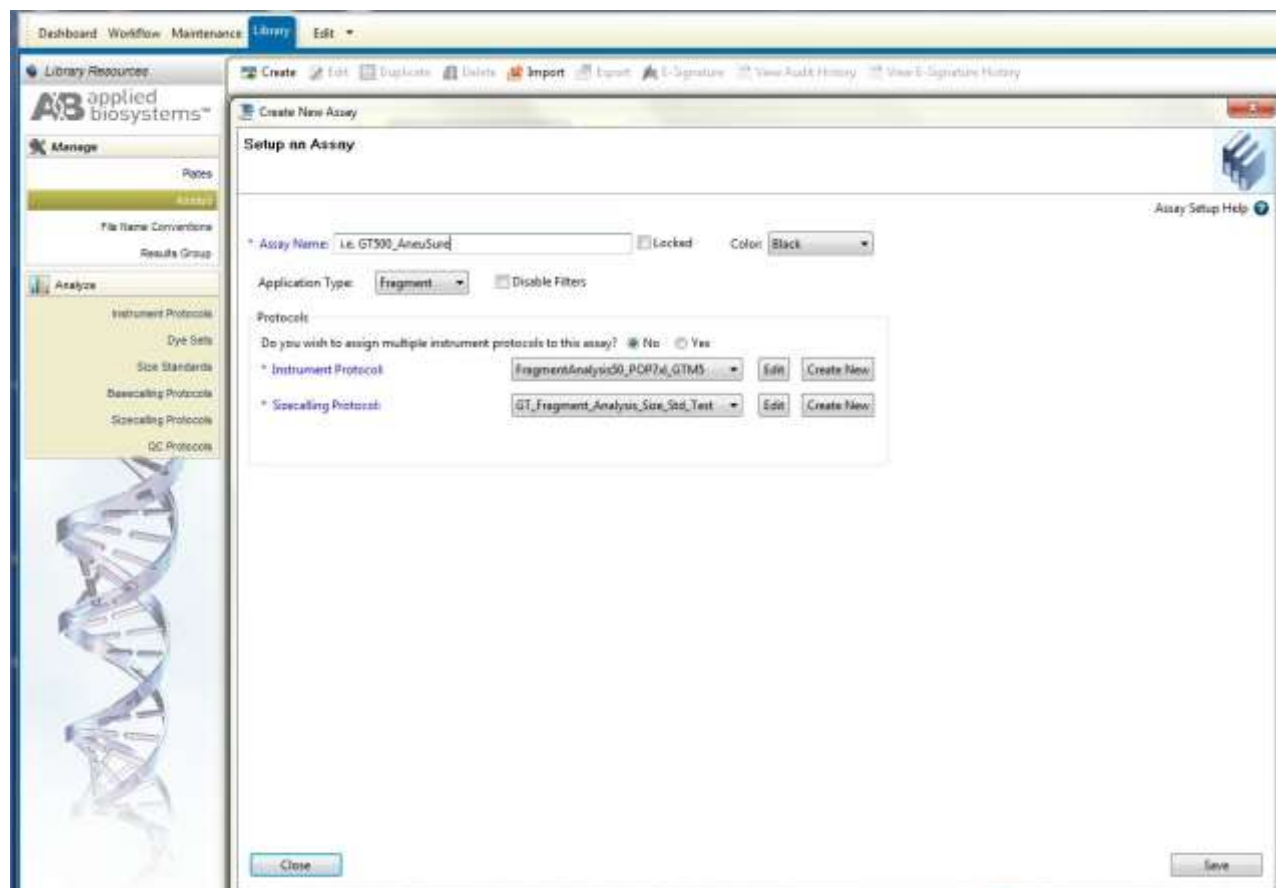

Figure 8. Screenshot for the “Create New Assay” window on Applied Biosystems 3500 Data Collection software

3.1.5. Create a new File Name Conventions

- a) Navigate to the Library
- b) Select “File Name Conventions”
- c) Select “Create” (Figure 9)

Data Collection Software will store this information (until there is a change in the physical properties of the instrument), and it can be used for subsequent runs.

- d) Choose the File Name Attributes according to your lab practices

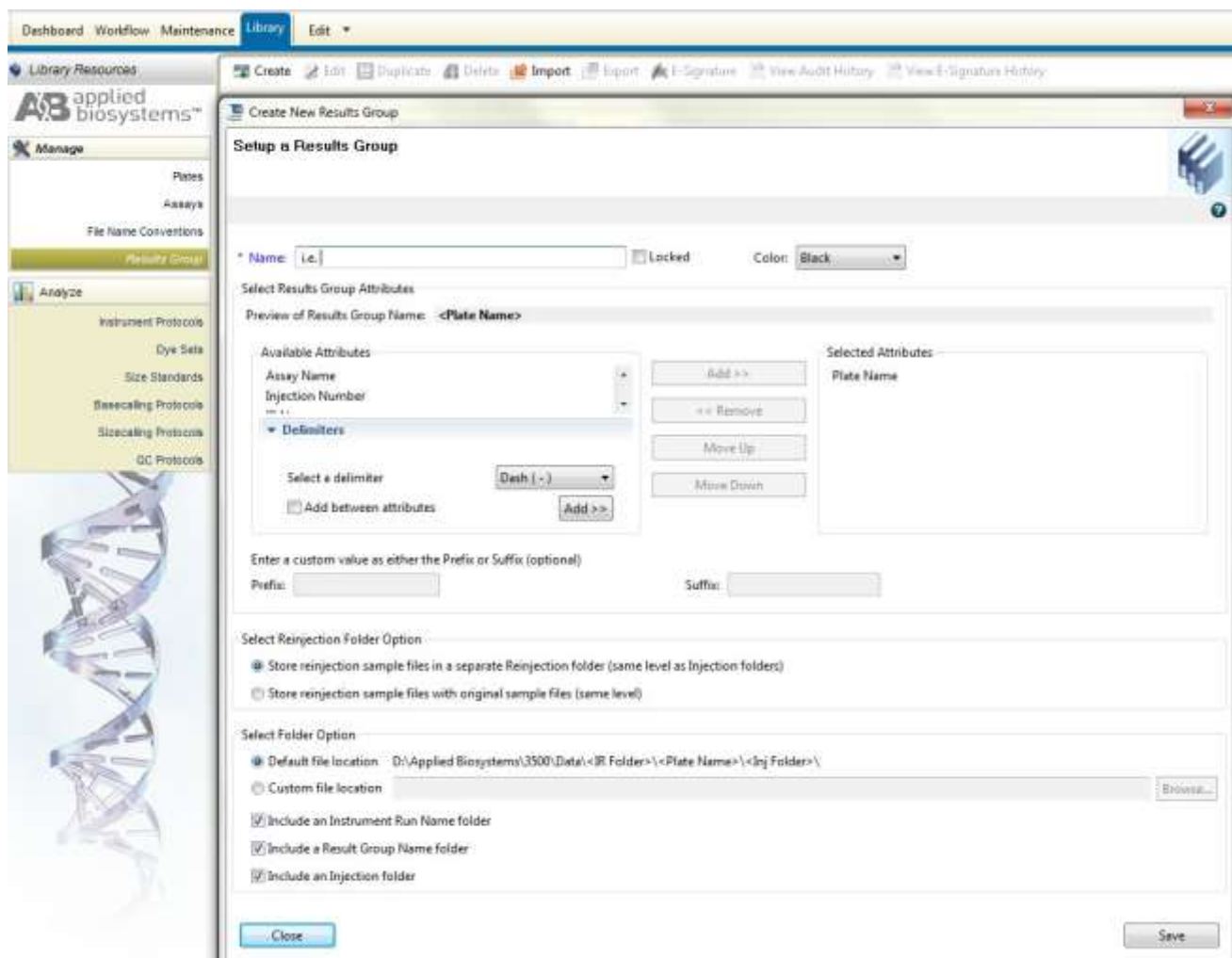

Figure 9. Screenshot for the “Create New File Name Convention” window on Applied Biosystems 3500 Data Collection software.

3.1.6. Create a new Result Group

- a) Navigate to the Library
- b) Select “Results Group”
- c) Select “Create” (Figure 10)

Data Collection Software will store this information (until there is a change in the physical properties of the instrument), and it can be used for subsequent runs.

- d) Choose the Results Group Attributes according to your lab practices

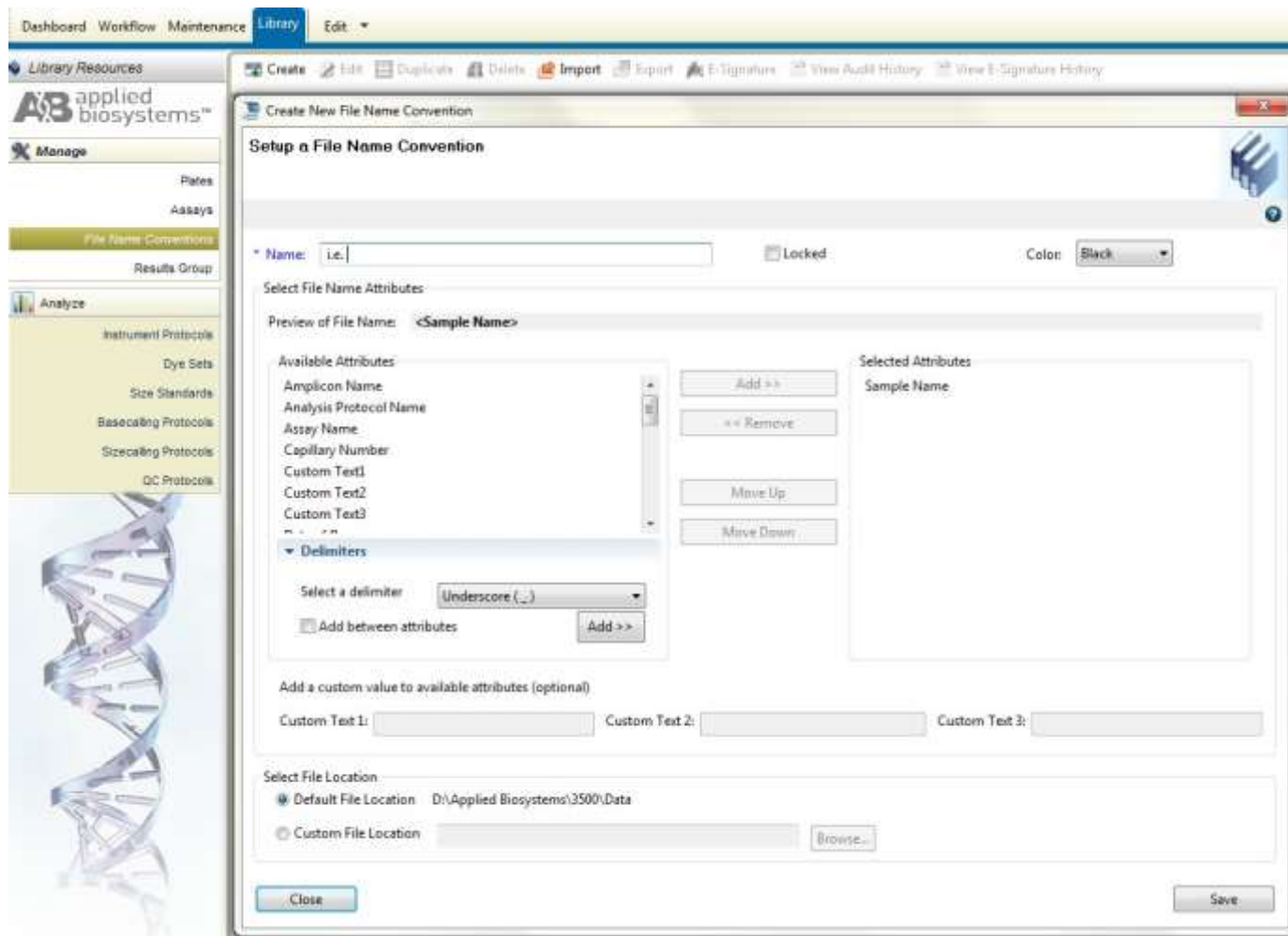

Figure 10. Screenshot for the “Create New Result Group” window on Applied Biosystems 3500 Data Collection software

3.1.7. Create a New Plate

- a) Navigate to the *Library*
- b) From the manage menu select “Plates”
- c) Select “Create” (Figure 11)
- d) Define a name for the plate
- f) Choose plate type “Fragment Analysis” from the drop-down menu



Figure 11. Screenshot for the “Defining plate properties” window on Applied Biosystems 3500 Data Collection software.

3.1.8. Select “Assign Plate Contents”

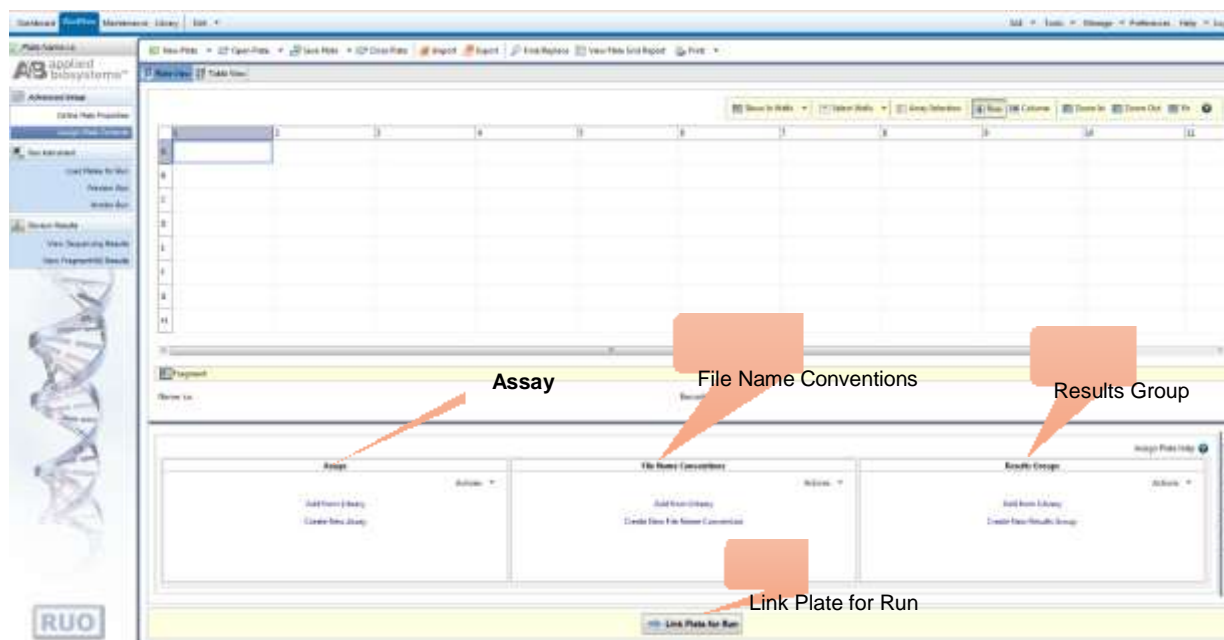

Figure 12. Screenshot for the “Assign Plate Contents” window on Applied Biosystems 3500 Data Collection software

- Define sample names to wells.
- In the *Assign Plate Window* (Figure 12), in the bottom left corner, in a box “Assay”, click Add from Library option to select the Assay created in Step 3.1.4. Click on the “Add to Plate” button and close the window.
- In the Assign Plate Window, in the bottom middle, in the box “File Name Conventions”, click Add from Library option to select the File Name Convention created in Step 3.1.5. Click on the Add to Plate button and close the window.
- In the Assign Plate Window, in the bottom right, in the box “Results Groups”, click Add from Library option to select the Results Group created in Step 3.1.6. Click on the Add to Plate button and close the window.
- Select the sample wells, then select the boxes in the Assay, File Name Convention and Results Groups that are relevant to those samples.
- Select “Link Plate for Run”. It will lead to open Load Plate window. Select “Yes”.
- In the Run Information window, give a Run name (Figure 13). Select “Start Run” after loading the plate.

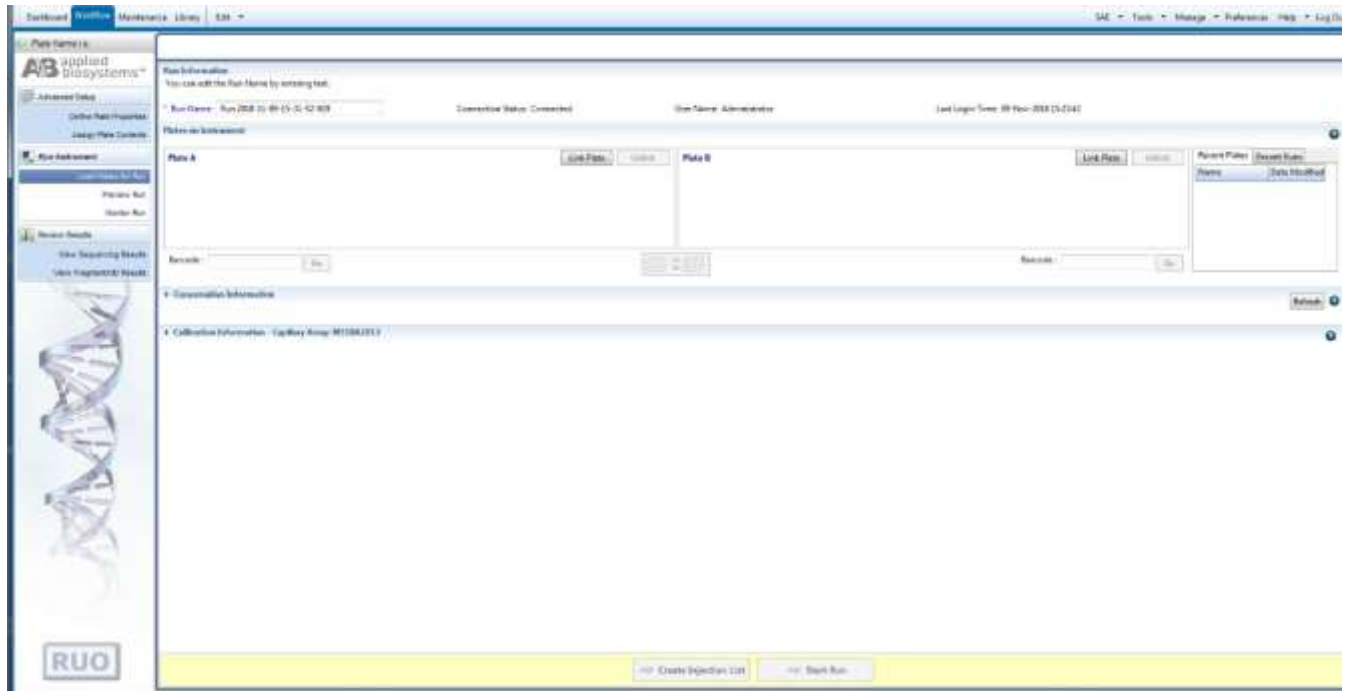

Figure 13. Screenshot for the “Run Information” window on Applied Biosystems 3500 Data Collection software

3.2. Instrument Preparation for Applied Biosystems® 3130/3130xl Genetic Analyzer (before the first use of GT Detector Kit)

Make sure that maintenance and installation of capillary array, buffers and polymer are done according to Applied Biosystems® 3130/3130xl Genetic Analyzer User Guide. Ensure that a spectral calibration is performed with GTM5 v2 Matrix Standard as mentioned above in this instruction in Capillary electrophoresis section. Before starting the electrophoresis for fragment analysis on the ABI Genetic Analyzer the following settings need to be set up in the instrument’s Data Collection Software; **Run Module**, **Instrument Protocol** and **Plate**. The instructions below are from an ABI 3130xl Genetic Analyzer with GT Detector as an example (Dye set: Any5Dye, GTM5 v2). The procedure is however similar to the other instruments. For further details, refer to the User Guide for the instrument used.

Attention:

Spectral Calibration must be made using GTM5 v2 Matrix Standard, the machine must be calibrated with

GTM5 v2 Matrix Standard. Please find detailed protocol for spectral calibration with GTM5 v2 Matrix Standard. CAT# 41103 or contact us at support@genetek.de.

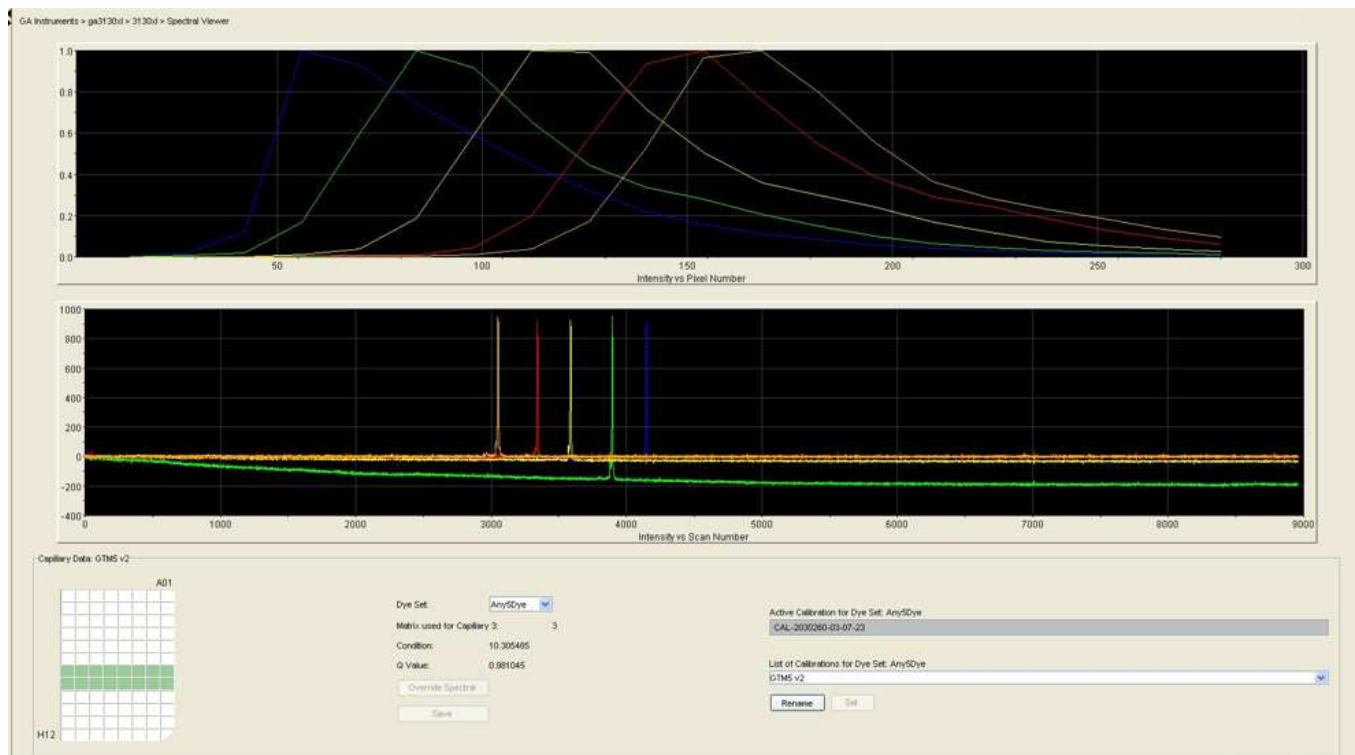

Figure 14. An example of a successful spectral calibration with GT 5-dye system on Applied Biosystems Genetic Analyzer 3130xl

3.2.1. Create a Run Module

In the left navigation window select Module Manager and New. Fill out the Run Module Editor according to the kit instructions for use (IFU).

- a) Name: Enter a name of the Run Module (GT Detector)
- b) Type: Regular
- c) Template: FragmentAnalysis50_POP7 (default template for the capillary array and polymer used)
- d) Click OK

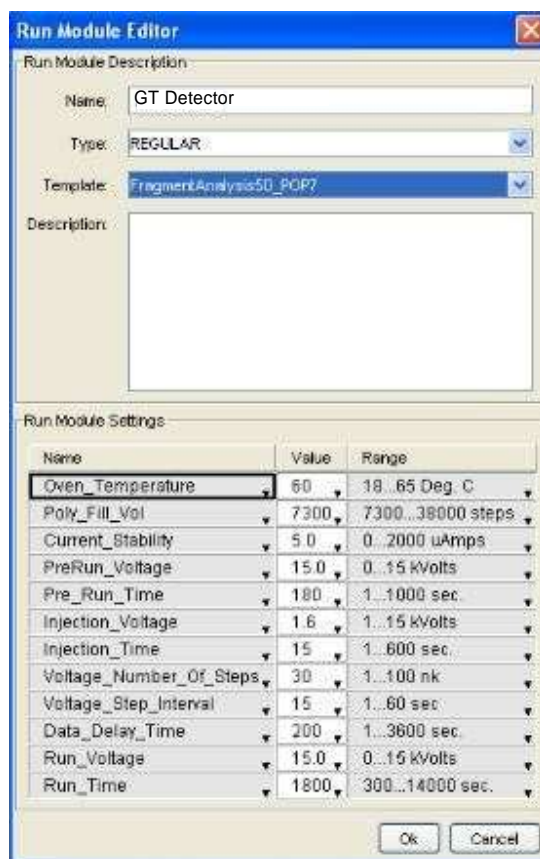

Figure 15. Screenshot for the “Module Manager” window on Applied Biosystems 3130 Data Collection software.

3.2.2. Create an Instrument Protocol

From the left navigation window select Protocol Manager and New.

- a) Fill out the Protocol Editor
- b) Name: Enter a name of the Run Module (GT Detector)
- c) Type: Regular
- d) Run Module: Select the Run Module created (GT Detector)
- e) Dye Set: Any5Dye
- f) Click OK

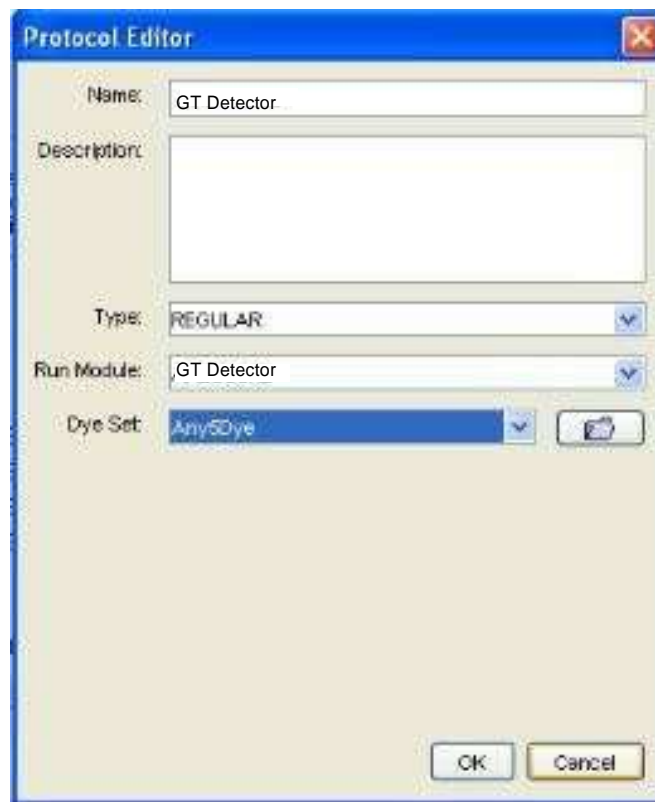

Figure 16. Screenshot for the “Create New Instrument Protocol” window on Applied Biosystems 3130 Data Collection software.

3.2.3. Set up a Plate for run

- From the left navigation window select Plate Manager and New.

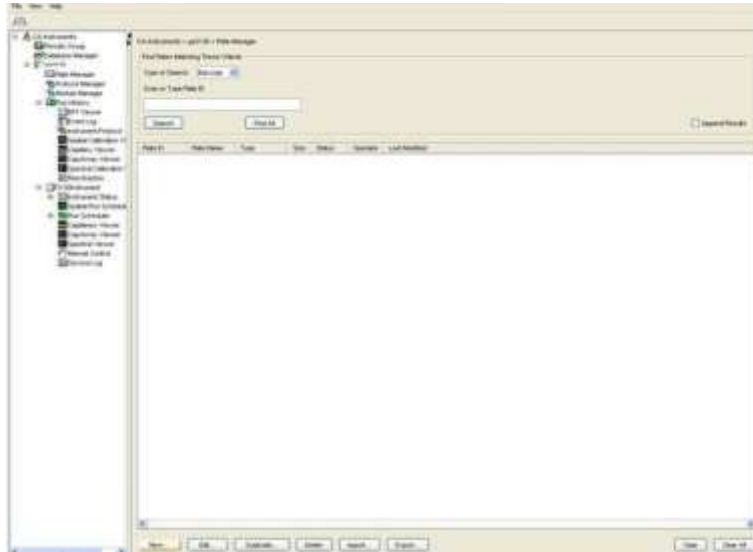

Figure 17. Screenshot for the “Plate Manager” window on Applied Biosystems 3130 Data Collection software

3.2.4. Fill out the New Plate Dialog

- a) Name: Enter a name of the plate
- b) Application: GeneMapper-Generic (used if data is analyzed on a separate computer)
- c) Plate type: 96-Well
- d) Owner Name: enter the name of the owner
- e) Operator Name: enter the name of the operator
- f) Click OK

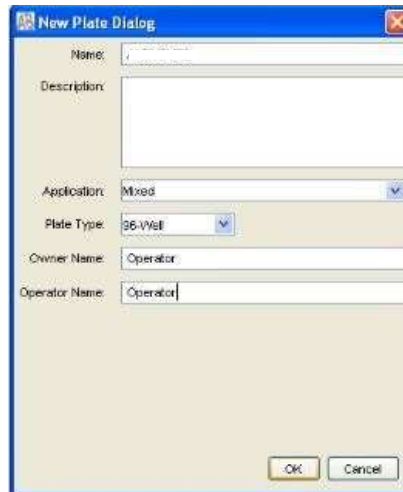

Figure 18. Screenshot for the “*New Plate Dialog*” window on Applied Biosystems 3130 Data Collection software

3.2.5. Fill out the GeneMapper Plate Editor

- a) Sample name: Enter the sample names
- b) Comment: optional
- c) Instrument Protocol 1: Select the instrument protocol that you created before
- d) Click OK

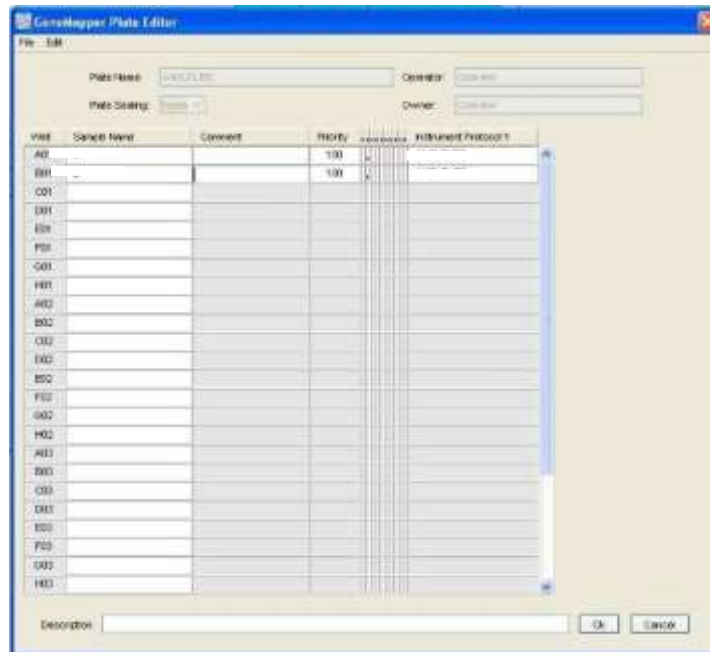
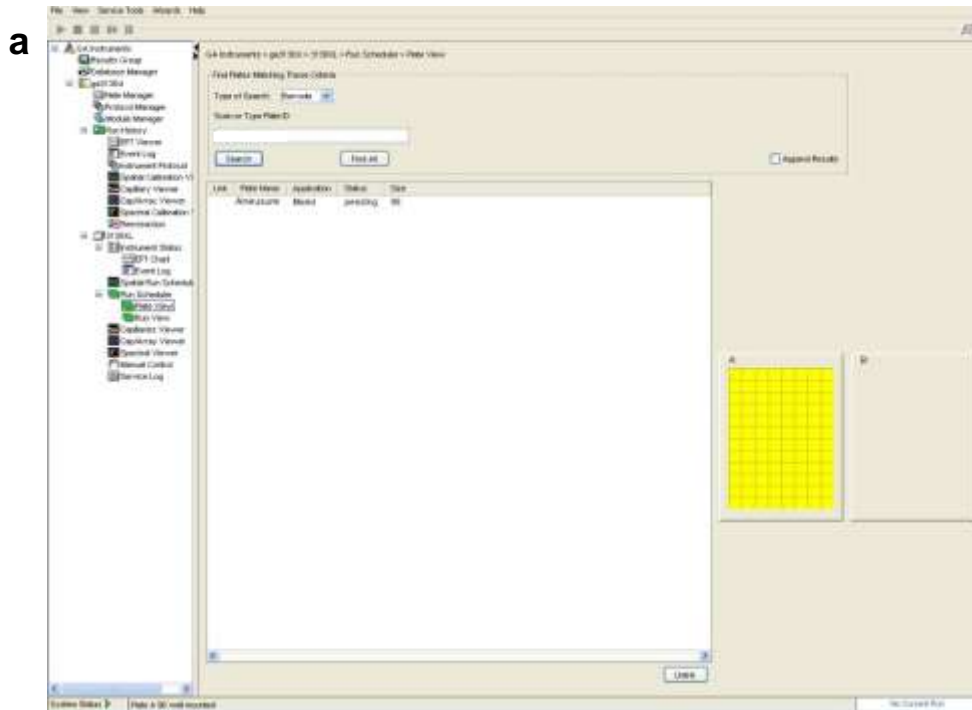

Figure 19. Screenshot for the “GeneMapper Plate Editor” window on Applied Biosystems 3130 Data Collection software.

- From the left navigation window, select Run Scheduler, search for GT Detector (plate name).



- Select the plate created in Step 3 (status pending). Link the plate by clicking on the yellow plate position indicator, which will turn green when linked. Start the run on the green arrow.

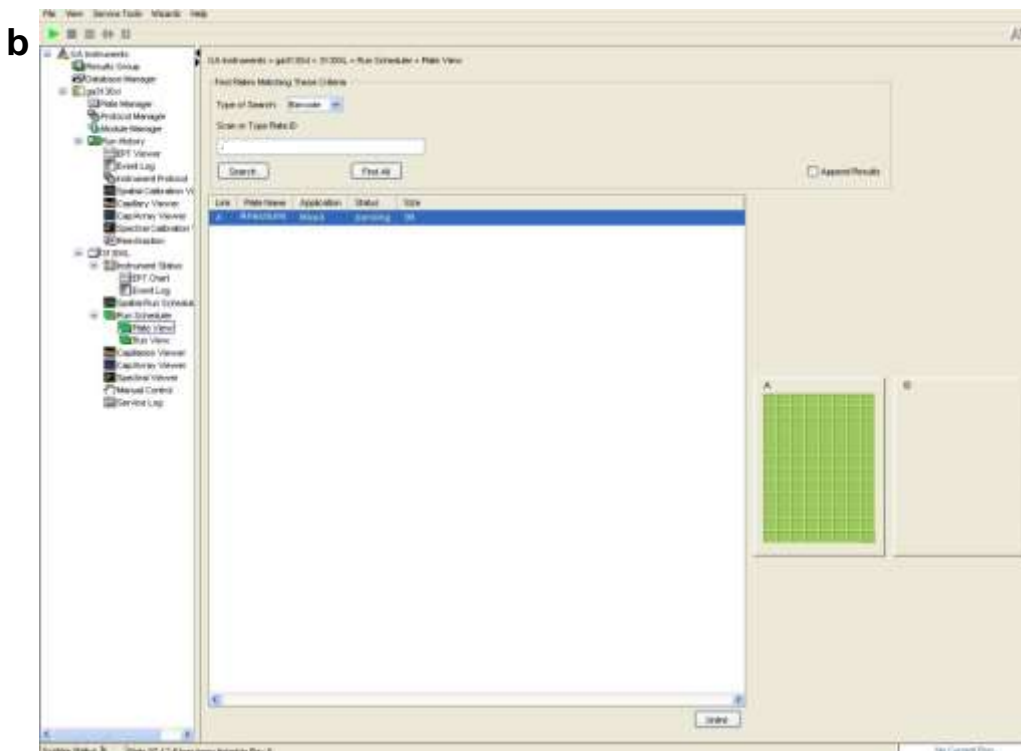

Figure 20 a & b. "Plate view" window on Applied Biosystems 3130 Data Collection software

- The Process Plates dialog box appears. Click OK to start processing the plate.



Figure 21. “Process Plates dialog” window on Applied Biosystems 3130 Data Collection software

3.3. Sample preparation for capillary electrophoresis (3500 Series and 3130 Series instruments)

Please note: The Size Standard used in the GT Detector kit is GT500.

- Vortex and spin 9.5 µL (X number of samples) Hi-Di™ Formamide and 0.5 µL GT500 (X number of samples) in a 1.5 mL tube. For every 8 samples prepare 10 since there may be pipetting error. The amounts below are for 10 injections.
- Pipette 10 µL of the prepared size standard mix to the required number of well and add 1 µL PCR product or GTD allelic ladder to it and use pipet to mix. Cover the wells with appropriate septa.
- Denature the PCR product by heating the plate in a thermal cycler. Set the cycler as:
 - 95°C for 5 minutes
 - 4°C for 30 seconds
- Place the PCR products on the ice (or cool box at -20) for 3 minutes
- Centrifuge the plate at 1,000xg for 10 seconds to remove any bubbles in the wells.
- Place the plate in the Genetic Analyzer and start run.

Please note:

- Detection limits for each instrument is different; hence, injection time, injection voltage or the amount of sample mixed with loading mix (Hi-Di™ Formamide and GT500 internal size standard) may need to be adjusted. Use the Module Manager in the data collection software to modify the injection time or voltage in the run module according to your lab validation (as mentioned in the instrument preparation above).
- In a multi-capillary Analyzer, injections take place simultaneously on all the capillaries. Therefore, 1 entire column (8 samples) or 3 entire columns (24 samples) must be pipetted onto the plate. If fewer samples are to be analysed, the empty well positions must be filled with 10µl Hi-Di Formamide.
- To get reliable allele call, inject at least one allelic ladder for each set of 24 samples (one allelic ladder per injection for 24-capillary instrument or one allelic ladder per 3 injections for 8-capillary instrument).
- Actual room temperature may influence the performance of the multi-capillary instrument which could result into shoulder peaks or split peaks, so make sure that the ambient conditions are maintained as described by the instrument manufacturer.

4. Result analysis and Interpretation

4.1. Software for sample analysis

- For GT Detector, the Applied Biosystems fragment analysis software compatible with your genetic Analyzer is recommended. This kit is compatible with GeneMapper® *ID-X* software. Analysis method depends on the software version.

Each Forensic lab should have individual interpretation and reporting procedure and criteria. To develop such procedure, we recommend Forensic lab to use SWGDAM guidelines for STR detection, interpretation, and contamination prevention. You can download it from - <https://www.swgdam.org/publications>.

4.2. General guideline for the analysis of GT Detector results

GT Detector PCR products are observed with 5-dye system on an electropherograms in the GeneMapper® *ID-X* software. For the analysis, import GT Detector panels. It can be downloaded from our website or contact us at support@genetek.de.

For detailed procedure on fragment analysis on GeneMapper® software please refer to the GeneMapper® *ID-X* user guide.

Table 6: Analysis parameters for GeneMapper® ID-X software

Parameter	
Peak detection algorithm	Advanced
Ranges	Analysis – Full Range, All Sizes Start Point – 0, Stop Point – 10000
Smoothing and baselining	Smoothing – Light Baseline Window – 51 pts
Size calling method	Local Southern Method
Peak detection	Minimum Peak Half Width – 2 Polynomial Degree – 3 Peak Window Size – 15

Note – In the Peak detection settings, the peak amplitude threshold (cut-off value) for each dye-channel should be determined by the individual laboratory but one should consider that the minimum peak height should be three-times higher than the background noise of the baseline.

Table 7: Template files to be used for analysis

File type	File name
Panels*	GT
Detector_panels BinSets*	
GT Detector_Bins Size Standard*	
GT500_SS	
Analysis method	Analysis_GTD_3130
	Analysis_GTD_3500
Plot settings	GTD_Plot

*User must utilize the Panels, BinSets and Size Standard files provided by GENETEK BIOPHARMA. Other files are optional.

Allocation of alleles depends significantly on finding the exact length of the PCR products. The later one depends on the device type, the condition of the electrophoresis and also on the Size Standard. The GT500 Size Standard should be used with the following horizontal size distribution: 60, 80, 100, 113, 120, 140, 160, 180, 200, 215, 220, 240, 260, 280, 300, 320, 330, 340, 360, 380, 400, 420, 430, 440, 460, 480 and 500 bp.

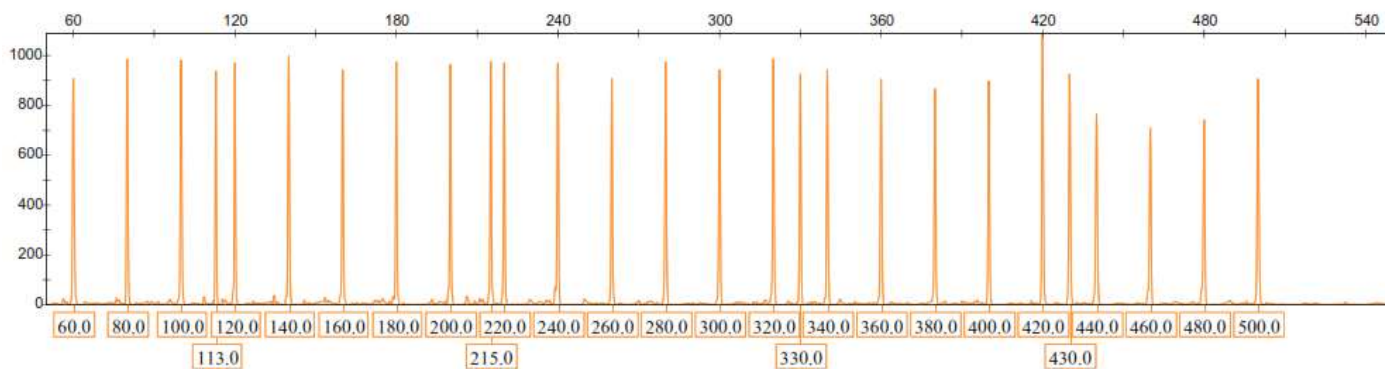

Figure 22. GT500 DNA Size Standard electropherogram on ABI 3500xL Genetic Analyzer

4.3. GT Detector Allelic Ladder

Allelic ladder development and validation has been performed using Applied Biosystems 3500 Genetic Analyzer with POP 7 polymer. Different analysis instruments, DNA size standard other than GT500 or polymer may result in different fragment lengths. Table 4 shows the alleles of the GTD allelic ladder.

Table 8: Allelic ladder fragments included in the GT Detector Kit

No.	Markers	Alleles used in GTD allelic ladder	GTQCDM (Control DNA) profile	GTQCDM102 (Control DNA) profile
1	AMXY	X, Y	X/Y	X/Y
2	D7S820	6, 7, 8, 9, 10, 11, 12, 13, 14	12/12	11/11
3	D21S11	25, 26, 27, 28, 29, 30, 30.2, 31, 31.2, 32.2, 33.2, 34, 34.2, 35	30/33.2	29/31
4	VWA	14, 15, 16, 17, 18, 19, 20, 21, 22	16/18	16/18
5	D3S1358	12, 13, 14, 15, 16, 17, 18, 19	16/16	17/17
6	D19S433	10, 11, 12, 13, 13.2, 14, 14.2, 15, 15.2, 16, 16.2, 17, 17.2, 18	13/14	13/14
7	D8S1179	8, 9, 10, 11, 12, 13, 14, 15, 16, 17	15/16	13/14
8	D13S317	8, 9, 10, 11, 12, 13, 14, 15	11/12	8/11
9	CSF1PO	7, 8, 9, 10, 11, 12, 13, 14, 15	11/11	10/12
10	D2S1338	16, 17, 18, 19, 20, 21, 22, 23, 24, 25, 26, 27	17/25	16/19
11	TH01	4, 5, 6, 7, 8, 9, 9.3	6/6	6/9.3
12	D5S818	7, 8, 9, 10, 11, 12, 13, 14, 17	11/11	11/11
13	TPOX	6, 7, 8, 9, 10, 11, 12, 13	8/11	8/8
14	SE33	8, 11, 16, 17, 18, 19, 20, 20.2, 21, 22, 23, 23.2, 24.2, 25.2, 26.2, 27.2, 28.2, 29.2, 30.2, 31.2, 32.2, 33.2, 34, 37	19/22	13/27.2
15	D16S539	8, 9, 10, 11, 12, 13, 14	12/13	9/11
16	D18S51	10, 11, 12, 13, 14, 15, 16, 17, 18, 19, 20, 24	12/15	14/15
17	FGA	17, 19, 20, 21, 22, 23, 24, 25, 26, 27, 28	22/23	21/25

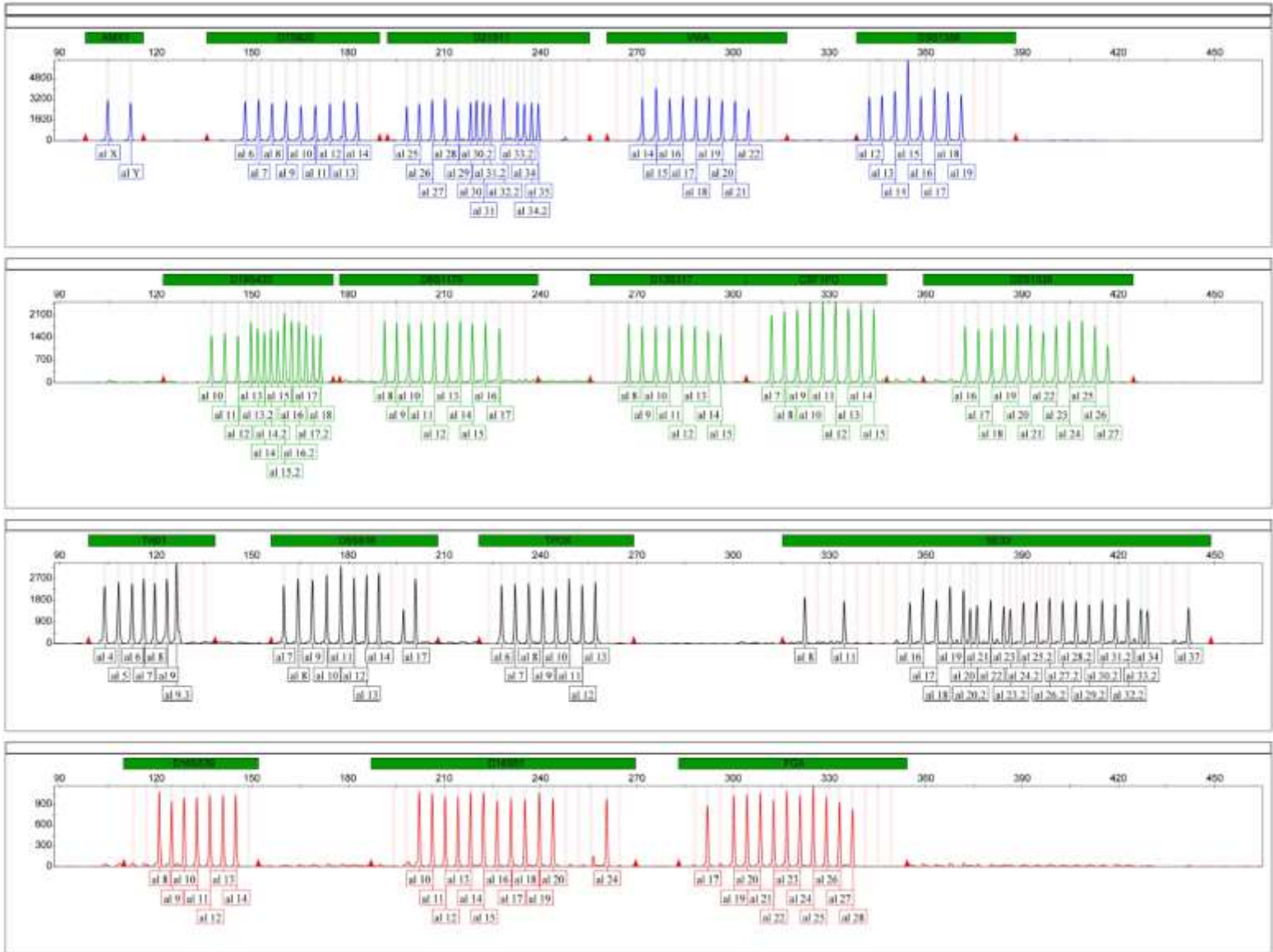

Figure 23. Electropherogram of the GTD allelic ladder. Allele assignment was performed using GeneMapper ID-X software

5. An example for GT Detector result

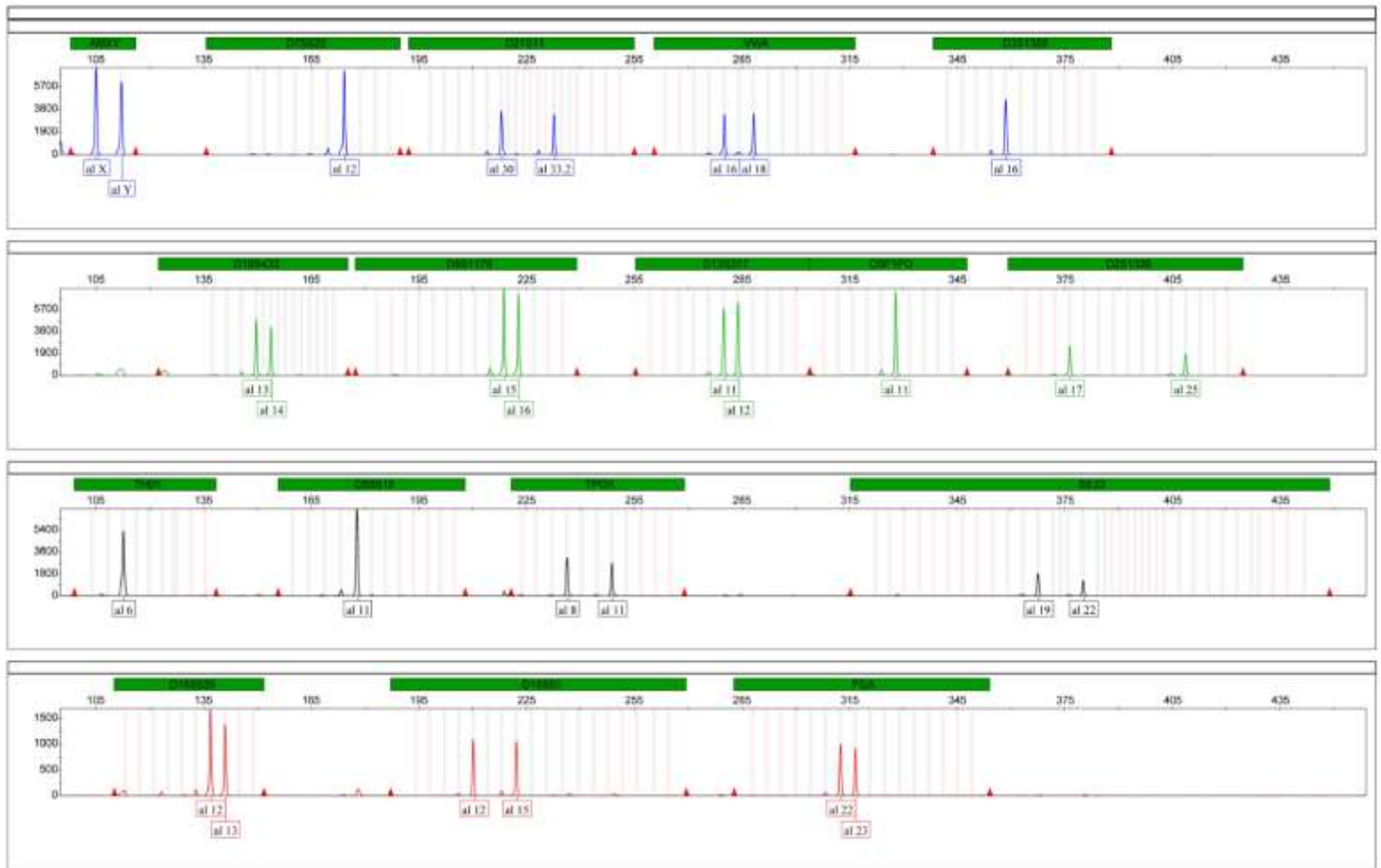

Figure 24. Electropherogram of the GT QCDM (Quality control DNA) showing male DNA profile analysed using GT Detector Kit. 1ng control DNA used as a template and Analysis was performed on an Applied Biosystems 3500xL Genetic Analyzer. Allele allocation was performed using GeneMapper *ID-X* software.

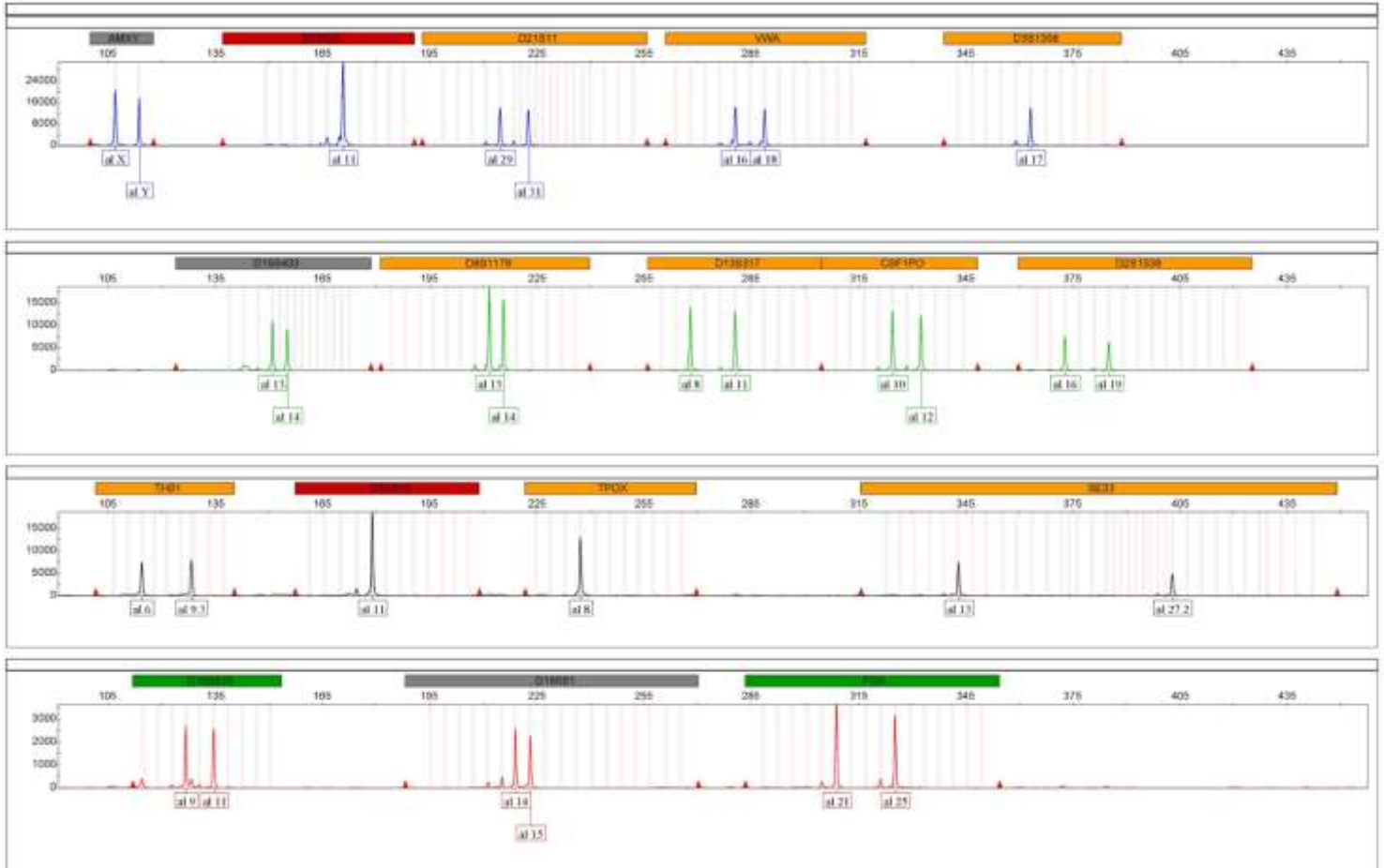

Figure 25. Electropherogram of the GT QCDM102 (Quality control DNA) showing male DNA profile analysed using GT Detector Kit. 1ng control DNA used as a template and Analysis was performed on an Applied Biosystems 3500xL Genetic Analyzer. Allele allocation was performed using GeneMapper ID-X software.

6. Troubleshooting

For any technical question or issue (not mentioned here) please contact our customer support here – support@genetek.de.

Issue Observed	Possible cause and Solution
No peak detection or faint peaks	<p>PCR reaction mix is not well mixed with enzyme and DNA. Vortex or use pipette to mix the PCR reaction mixture after adding DNA.</p>
	<p>An air bubble formation in the reaction tube can cause poor mixing of reaction mixture. Use a pipette to remove the air bubble or centrifuge the reaction mixture before thermal cycling.</p>
	<p>Poor amplification due to improper thermal cycling. GT Detector Kit amplification protocol is validated using Eppendorf Mastercycler® nexus. Individual lab must perform internal validation for different thermal cycler to confirm the cycling protocol.</p>
	<p>Poor capillary electrophoresis injection if faint peaks for GT500 Size Standard is also observed. Re-inject samples or increase injection time.</p>
	<p>Lower quality formamide was used. Use only the recommended formamide.</p>
	<p>Run quality control GT QCDM102 provided with GT Detector Kit to check the efficiency of the primer mix and other PCR reagents.</p>
<p>Inhibition of PCR because of too much template or other impurity in DNA extraction. Check the quality and quantity of extracted DNA. Use only the recommended DNA concentration. Make sure DNA is not degraded.</p>	

Extra peaks observed in one or more dye channels

Amplification of STRs can result in artifacts that seems as peaks one base smaller than actual peak due to incomplete addition of the 3' "A" residue.

To avoid this phenomenon, we recommend:

- a) Make sure to perform complete extension step as described in the protocol.
- b) Decrease the amount of DNA template in the reaction, too much DNA can lead to incomplete adenylation.
- c) Make sure reaction is not over amplified, decrease cycle number. Eventually each lab should perform internal validation for cycling condition.

Pull-up or bleed-through because of too high peaks. Make sure that analysis method is performed using GTM5 v2 Dye Set Spectral Calibration.

Check if Spectral Calibration results are acceptable. See instructions in instrument preparation in section 3.

Samples not denatured completely, perform denaturation step as recommended.

Cross contamination with another sample DNA or PCR reagent is contaminated with amplicons. Use aerosol-resistant pipette tips, change gloves for pre- and post- PCR steps.

Store reagents in appropriate (Pre- and Post-) storage space. Do not open pre - PCR reagent tubes in Post-PCR lab.

Long-term stored PCR products are used.

Polymer-caused artifacts, check Polymer expiration date and storage time as mentioned in the manufacture guide.

Off-scale peaks

If off-scale peaks after primer peaks are observed –

- a) Excessive DNA is added as template. Prepare new reaction with diluted DNA to repeat the PCR and capillary electrophoresis.
- b) Excessive size standard in sample. Prepare new reaction using less size standard and repeat electrophoresis run.

No sizing data or size quality fails

- a) Incorrect size standard selected or no size standard selected in analysis method or protocol editor. Make sure that size standard option is edited with GT500 Size Standard.
 - b) Incorrect size standard is used. We recommend using GT500 with GT Detector Kit to obtain optimum results.
-

7. Limitations and Disclaimer

Any result obtained from GT Detector or any other Kit should be used and interpreted by qualified person. GENETEK BIOPHARMA GmbH cannot bear any responsibilities for false use and interpretation being made by any lab. The results obtained by GT Detector or any other Forensic Kit should not use for diagnostic purpose and only be used as mentioned in intended use, hence GENETEK BIOPHARMA GmbH cannot be responsible for any clinical decisions made by the user or client lab.

GT Detector Kit is designed to be used for forensic, human identification and paternity testing. It will not detect chromosome abnormalities or defect. User must carefully inspect any case of sample mix-up and cross-contamination before interpretation and consultation.

Result analysis guideline is generated using set of samples from specific populations. User lab should perform internal validation for any specific population for heterozygosity in each population.

We recommend that individual laboratory performs and develops its own test procedure and interpretation standard operative procedure. Best practice guidelines as mentioned in following section can be used to generate such documents.

GT Detector Kit is for Research Use Only and user bears all the responsibility for its use in diagnostics. Please consult best practice guidelines when using any forensic kits including GT Detector Kit.

8. General Safety Warnings

- Any procedure should be performed by professional/qualified personal.
- Care should be taken while handling any human origin material, all samples should be considered potentially infectious. Lab technician or person handling the DNA must follow good lab practice and safety guidelines.
- Store all the components as described in the user guide.
- Laboratories should test their own quality check samples for each type of the assay to validate the Kit procedure.

Chemical safety

- Before handling any chemicals, refer to the Safety Data Sheet provided by the manufacturer and follow relevant precautions.
- Minimize the contact with chemicals. Wear appropriate personal protective lab wear i.e. safety glasses, protective clothing, gloves.
- Check for chemical leaks and spills.
- Comply with local regulation regarding chemical storage, handling and disposal.

SDSs

- The SDS for each of the Kit component is available online at GENETEK BIOPHARMA GmbH website <https://genetek-biopharma.com/>.
- Any request for specific SDS can also be made from support@genetek.de.

9. Symbols used on labels and packaging

Description Symbol

Read Instructions before Use



Do not use after the year, month and date mentioned



Manufacturer name and address



Storage temperature limit – Upper and Lower



Manufacturer's Catalogue number



Manufacturer's Batch code or Lot number



10. Further Reading

1. DNA Fragment Analysis by Capillary Electrophoresis User Guide by Applied Biosystems® Publication Number 4474504.
2. Best Practice Guidelines for Internal Quality Control in Genetic Laboratories by Association for Clinical Genetic Science.